

# HLV304M

**Custom-made  
design  
available!**

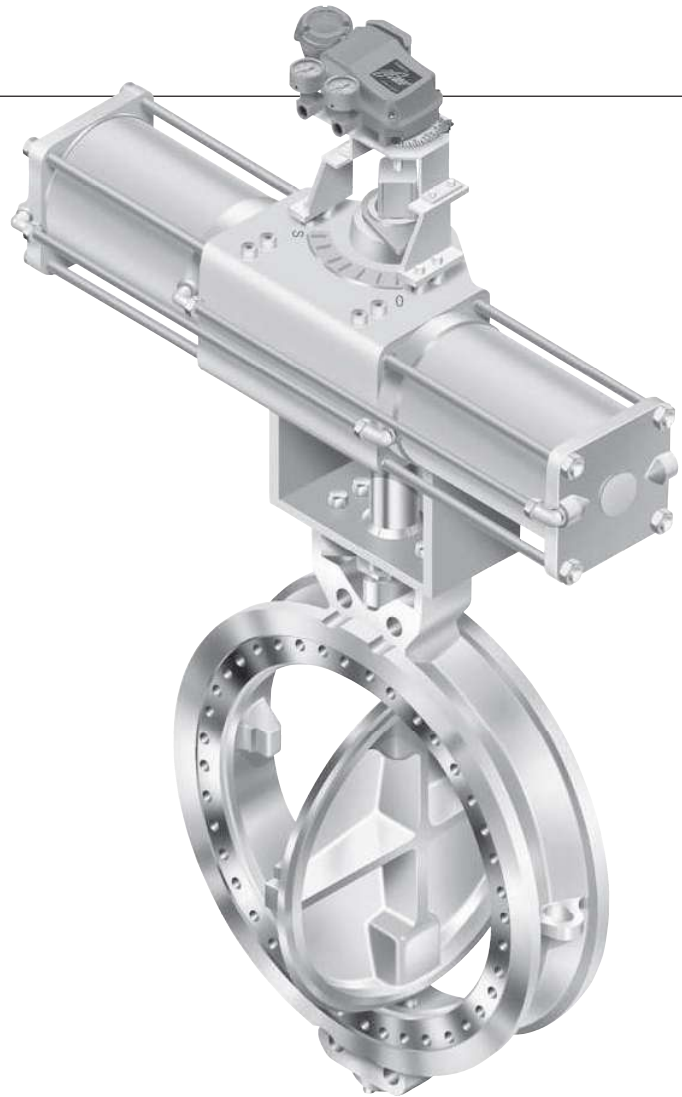

## Characteristics

Suitable for high-temperature, medium-to low- pressure service, such as in hot air, exhaust gas, steam, chemical fluids, and solvents.

### Compact Design

Short pattern face to face dimensions. The body and disc design contributed to a valve that is lower in weight and more compact than other valves of this type.

### Double Offset Geometry

The axis of disc rotation is double offset to the seat. When the disc rotates, it unseats at a small turning angle by its cam effect. This prevents seat wear and provides reliable sealing performance over a long period.

### Simple Sealing Design/Reliable Performance

The simple sealing design with a minimal number of parts allows easy maintenance without special tools. Tight shut off with an RPTFE seat is available. See PT rating chart.

### Custom-Made Design

Custom made designs, including the use of special materials, a double flanged body or special face to face dimensions are available upon request. A metal seat type is also available.

### 304M PT Rating (RTFE SEAT)

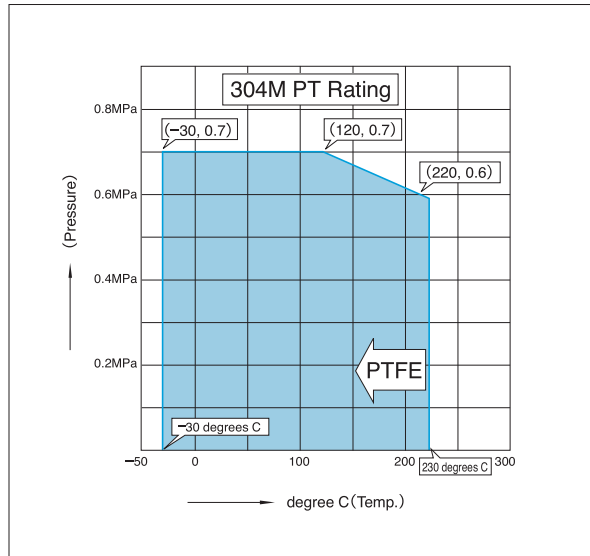

※No actuator extension bonnet is required.

### 304M Cv Value

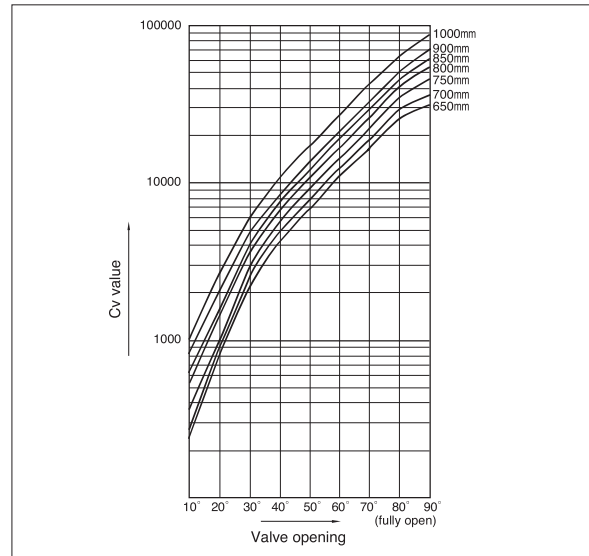

### Standard Specifications

Product characteristics		Double offset wafer type	
Valve size		650, 700, 750, 800, 850, 900, 1000mm	
Face to face dimensions		JIS 5K, 10K, ASME Class150 Series A or B, DIN/BS PN10	
Max.working pressure ※1		Manufacturer's standard	
Seat leakage		0.7MPa	
Flow direction		ISO 5208 leakage rate A (tight shut-off)	
Test Pressure	Shell test	Flow to shaft side. (Max. 0.2MPa on non-preferred direction)	
	Seat leakage	Working pressure x 1.5 times (Max 1.1Mpa)	
Working temperature range ※2		Working pressure x 1.1 times (Max 0.8Mpa)	
Standard materials	Body	Carbon steel casting SCPH2/WCB with Mn3 (PO4) 2 treatment	Stainless steel SCS13A/CF8, SCS14A/CF8M
	Disc	Stainless steel SCS13A/CF8 with Cr.plating, SCS14A/CF8M with Cr. Plating	Stainless steel SCS13A/CF8 with Cr.plating, SCS14A/CF8M with Cr. Plating
	Stem	Stainless steel 431, 630, 316	
	Seat	RPTFE	
	Gland packing	Carbon graphite	
Velocity range		Average velocity: 80m/s (air), 30m/s (steam), 2m/s (water) ※3	
Marking		API609, MSS-SP25, JIS B 2004	
Piping flange gasket		Serrated spiral 45 to 55 groove/inch for gasket face finish, unless otherwise specified	
Coating		Silicon resin coating (Grey N7) for 200 degrees C or lower. Heat resistant silver coating for over 200 degrees C. No painting for stainless steel.	

※1 Recommended piping position: shaft horizontal position

※2 Max. working pressure & temperature range are subject to change depending on customized specifications.

※3 Consider according to individual specifications.

※ It is possible that seat leakage occur when fluid (e.g. powder and/or liquid) is solidified by working temperature and other cause. Consult us.

Please note that use with vertical line such as bottom area of discharge spout of hopper, and tank.

Butterfly Valve

TRITEC

TT2

334A

344Q

302A/303Q

304A/304Q

304YA

302Y/304Y

304M

(HLV)

507V/508V

DTM

846T/847T/847Q

841T/842T

700Z

700G/704G/705G

72WG/72SG/72LG

731P/732P/  
732Q/752W

731R

700E/700K/700S

704G/722F/720F

227P

907T/908H  
(MKT)

903L/901C/  
905C (Bata-check)

# HLV 304M

## HLV 304M Principal dimensions

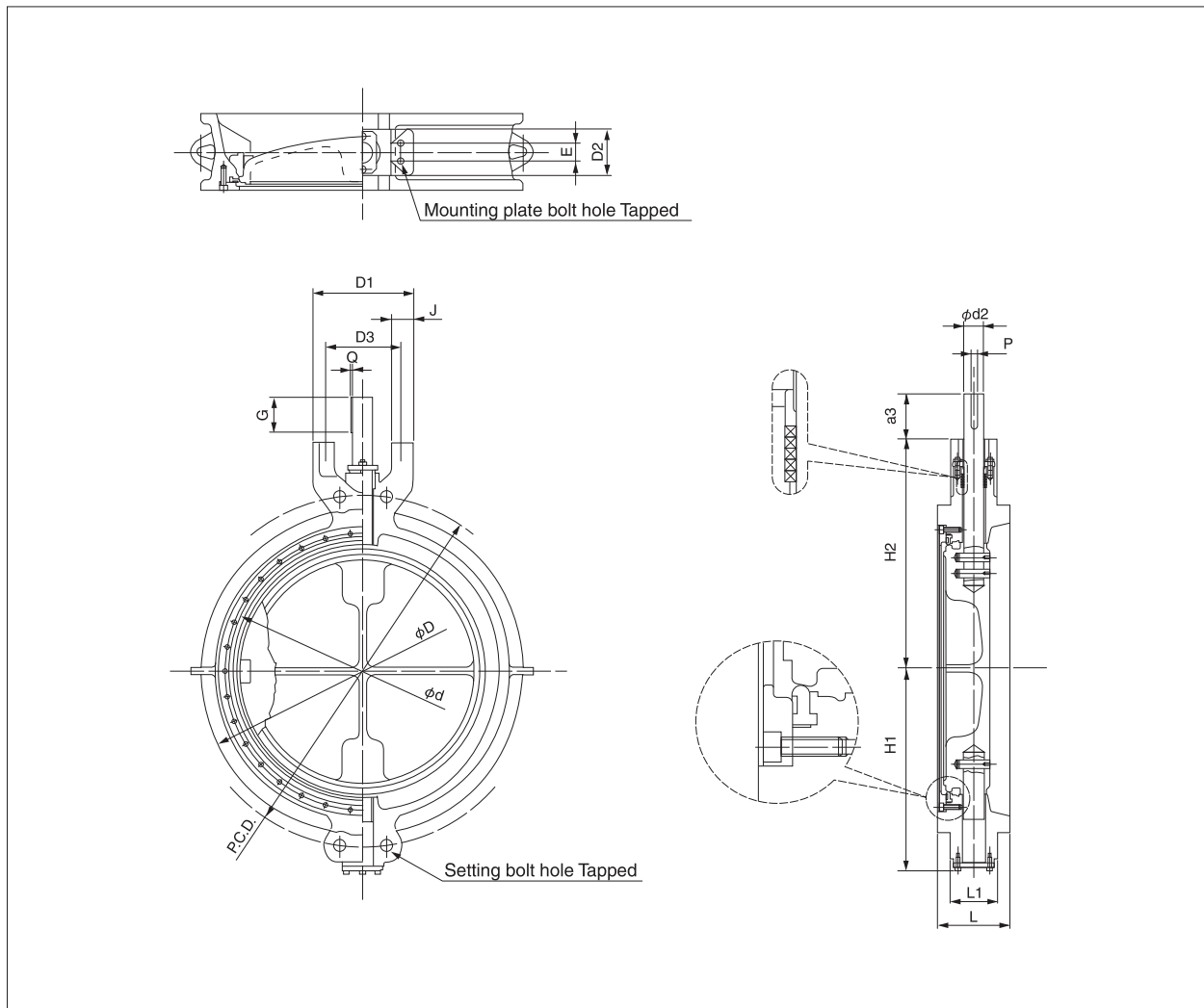

Nominal size		Dimension (mm)																Approx. Mass (kg)
mm	inch	d	D <sup>*1</sup>	L	L <sub>1</sub>	H <sub>1</sub>	H <sub>2</sub>	a <sub>3</sub>	d <sub>2</sub>	D <sub>1</sub>	D <sub>2</sub>	D <sub>3</sub>	E	J	G	P	Q	
650	26	653	739	165	105	459	520	117	45	230	105	175	40	50	79	14	3.5	218
700	28	702	770	165	132	531	655	145	55	430	132	380	90	55	121	16	4	285
750	30	754	843	180	132	546	690	145	60	430	132	380	90	55	121	18	4	365
800	32	801	893	190	132	579	705	145	60	430	132	380	90	55	121	18	4	407
850	34	853	943	203	143	591	720	175	65	430	143	380	90	55	151	20	4.5	460
900	36	903	993	203	137	621	750	175	65	430	137	380	90	55	151	20	4.5	505
1000	40	1000	1093	216	148	676	800	175	70	430	148	380	90	55	151	20	4.5	730

\* Indicates JIS 5K value.

## HLV 304M Typical Actuator Selection Chart

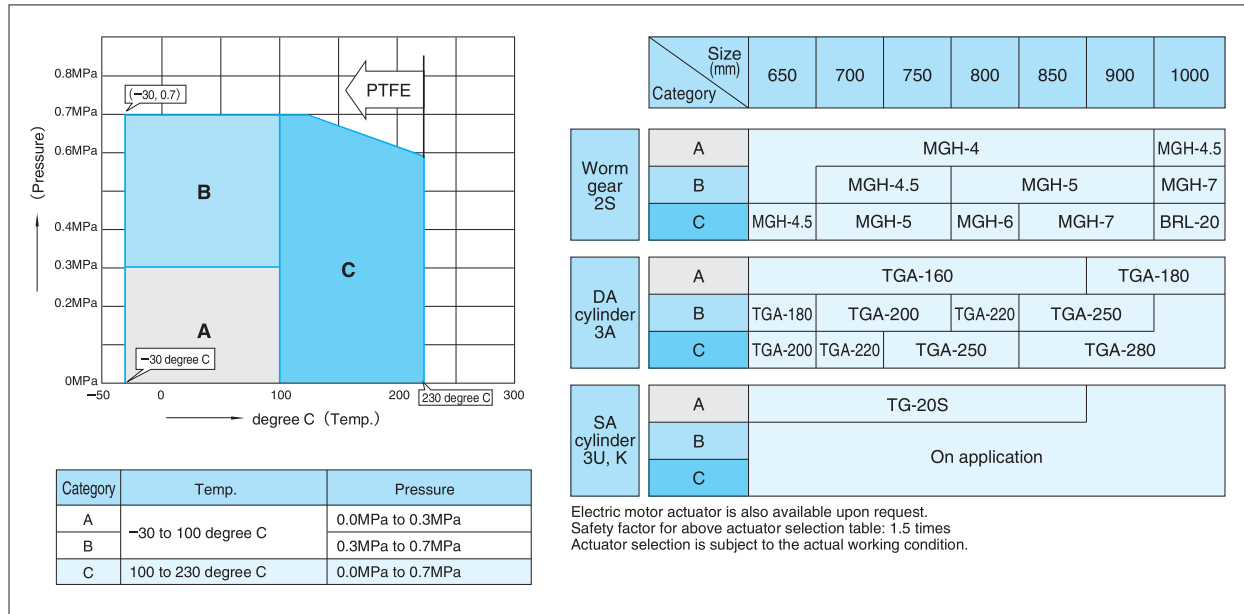

## HLV 304M Flange accommodation

Nominal size		Flange Standard									
mm	inch	JIS5K	JIS10K	ASME A	ASME B	DIN 10	BS	TAYLOR	LADISH	G5524	BS 10
650	26	○	○	○	○	—	—	△	△	×	×
700	28	○	○	○	○	○	○	△	△	△	×
750	30	○	○	○	○	—	○	△	△	×	△
800	32	○	○	○	○	○	○	△	△	△	×
850	34	○	○	○	○	—	—	△	△	×	×
900	36	○	○	○	○	○	○	△	△	△	△
950	38	—	—	○	○	—	—	△	△	×	×
1000	40	○	○	○	○	○	○	△	△	△	×

JIS5: JIS B2238 (1996)  
 JIS10: JIS B2238 (1996)  
 ASME A: ASME B16.47-1990 table 5 dimensions of class 150 series A flanges  
 ASME B: ASME B16.47-1990 table 11 dimensions of class 150 series A flanges  
 DIN 10: DIN 3532 PN10  
 BS: BS 4504 NP10  
 TAYLOR: TAYLOR FORGE 125, 150Lb  
 LADISH: LADISH150  
 G5524: JIS G 5524  
 BS 10: BS 10 TABLE E

○ : Applicable  
 △ : Applicable subject to conditions  
 — : Not standard  
 × : Not applicable

## HLV 304M Minimum Internal Diameters of Piping

Nominal size		Minimum internal diameters of piping A (mm)
mm	inch	
650	26	612
700	28	653
750	30	705
800	32	754
850	34	803
900	36	834
1000	40	950

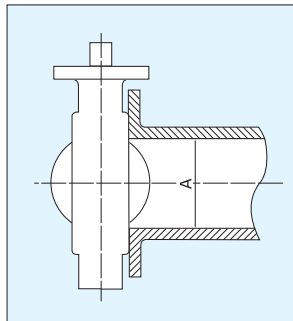

Butterfly Valve

**TRITEC**

**TT2**

**334A**

**344Q**

**302A/303Q**

**304A/304Q**

**304YA**

**302Y/304Y**

**304M (HLV)**

**507V/508V**

**DTM**

**846T/847T/847Q**

**841T/842T**

**700Z**

**700G/704G/705G**

**72WG/72SG/72LG**

**731P/732P/732Q/752W**

**731R**

**700E/700K/700S**

**704G/722F/720F**

**227P**

**907T/908H (MKT)**

**903L/901C/905C (Bata-check)**